

From connective actions in social movements to offline collective actions: an individual level perspective

Role of connective actions for mobilisation

205

Edward W.N. Bernroider
*Department of Information Systems and Operations Management,
Vienna University of Economics and Business, Vienna, Austria*

G. Harindranath
*School of Management, Royal Holloway, University of London,
Egham, UK, and*

Sherif Kamel
The American University in Cairo, Cairo, Egypt

Received 12 August 2020
Revised 12 July 2021
11 January 2022
4 March 2022
Accepted 6 March 2022

Abstract

Purpose – The purpose of this study is to investigate the role of connective action characterised by interconnection and personal communication on social media (SM) for participating in collective action in the physical world of social movements.

Design/methodology/approach – A research model is developed integrating different modes of connective action into the social identity model of collective action (SIMCA) to investigate pathways to participating in offline collective action (CA) from an individual perspective. Following a survey design approach, data collected from 194 respondents in the background of Egypt's social movements are examined using partial least squares (PLS) path modelling and mediation analyses.

Findings – The authors' main results reveal that interactive socialisation (IS) on SM provides an important momentum for the user to internalise (consume) and externalise (share) content online from a social learning perspective. In terms of translating these activities to participating in offline CA, the authors find support for two independent causal chains: An "instrumental" chain building on content externalisation (CE) and efficacy considerations and an "obligatory" chain based on content internalisation (CI) and collective identity.

Originality/value – The authors' results highlight the individual-level origins of offline mobilisation in social movements, which are not only grounded in social-psychology, but also develop out of interrelated connective actions supporting social learning. Prior work has mainly conceptualised the value of SM in social movements for online political communication. The authors' conceptualisation is novel in terms of integrating online and offline behaviours with social-psychological perspectives and the application with primary data in a protest movement context that heavily relied on connective actions for offline mobilisation.

Keywords Social network sites, Social media, Social movements, Connective action, Collective action, Egypt
Paper type Research paper

1. Introduction

This study focusses on social movements as "purposive collective actions whose outcome, in victory or defeat, transforms the values and institutions of society" (Castells, 2004, p. 3). Current research emphasises that SM have become important instruments for people to communicate and facilitate such collective actions (Pandey *et al.*, 2019). This in particular



© Edward W.N. Bernroider, G. Harindranath and Sherif Kamel. Published by Emerald Publishing Limited. This article is published under the Creative Commons Attribution (CC BY 4.0) licence. Anyone may reproduce, distribute, translate and create derivative works of this article (for both commercial and non-commercial purposes), subject to full attribution to the original publication and authors. The full terms of this licence may be seen at <http://creativecommons.org/licenses/by/4.0/legalcode>

holds true for the uprisings in Egypt, where a large disparate network of individuals used SM platforms to create and consume information relevant to the movements (Harindranath *et al.*, 2015; Maghrabi and Salam, 2013). However, the general ability of SM to foster mobilisation (to advance or resist social change) is still debated (Grejdanus *et al.*, 2020). Whilst most of the empirical evidence supports the view that SM represent an alternative structure alongside mainstream media and other well-established channels to reach out to and mobilise different segments of the population (Enjolras *et al.*, 2013; Skoric *et al.*, 2016), another stream of research has characterised SM-based social movement participation as “slacktivism” (Morozov, 2011; Wilkins *et al.*, 2019). These studies suggest that certain online actions may have a demobilising role, decrease mobilisation for required supplementary (offline) actions or prevent future engagement for other causes. Recent experiments confirm this view, at least, for short-time engagements for the same cause (Schumann and Klein, 2015). The common ground seems to be that mobilisation effects depend on circumstances, such as past behaviour and perceived efficacy (Wilkins *et al.*, 2019).

Despite these developments, most prior information systems research has largely focussed on how SM affords people the ability to engage in collective actions through “connective actions” to interconnect and propagate information (Bennett and Segerberg, 2012; Vaast *et al.*, 2017; Azer *et al.*, 2019; Nekmat and Ismail, 2019; Bernroider *et al.*, 2016) and engage in new forms of political participation (Pandey *et al.*, 2019) or communicative discourses (Shirazi, 2013). Whilst these studies are helpful to better understand online spaces as collective creations of ideas, ideals and suggestions, they are largely silent on whether how or under which conditions connective actions support or restrict further (offline) actions in support of social movements. The general issue of how and when SM effectively supports social transformations is both theoretically and practically important. If citizens are collectively able to effectively leverage SM for social or political causes, they are likely to participate in important decisions affecting their lives (Borrero *et al.*, 2013) or even bring about greater economic equity and curtail corruption, especially in developing economies (Lee *et al.*, 2018). Individual-level analyses of these matters are still rare (Grejdanus *et al.*, 2020).

Furthermore, prior work still places a relatively larger focus on the role of social movement organisations (e.g. Selander and Jarvenpaa, 2016) instead of considering individual citizens and their needs. Social movement organisations link their goals with the preferences of social movements and try to implement these goals (McCarthy and Zald, 1979). However, in an increasingly connected world, such organisations are likely to have less-prominent roles or may even be no longer required as a central governing entity. Recent research reported the emergence of new forms of decentred, emergent and collective leadership (Azer *et al.*, 2019), which in particular challenges our understanding of the methods and online behaviours required to affect mobilisation in contemporary social movements.

Consequently, this study aims to fill a gap in literature by specifically addressing the following research question in the context of social movements: *Whether and under which conditions connective actions foster offline CAs from an individual level of analysis?* Theoretically, we incorporated connective actions into SIMCA (Van Zomeren *et al.*, 2008), which synthesises three strands of social psychology literature and suggests that perceived injustice, efficacy and social identity can predict collective action. Empirically, we implemented a quantitative study drawing on primary data collected during the political uprising in Egypt between 2011 and 2013 to test our research model. This case allowed us to investigate conditions of individual action in the physical world, since there is an agreement that a large community of disparate people used SM as an online space to formulate and propagate the protest movement, which then spread offline and toppled the regime (Lim, 2012; Agarwal *et al.*, 2012; Maghrabi and Salam, 2013). It is important to note that it is outside the scope of this article to offer a review of all the political, economic and historical

trajectories leading to the uprising. In terms of data analysis, we applied PLS-SEM and mediation tests to investigate the extent to which the proposed causal variables directly or indirectly affect individual behaviour.

2. Theoretical background

The concept of collective action, defined as any activity of common or shared interest amongst a group of individuals to advance a common goal (Olson, 1965), offers a very useful lens to understand when, why and how people engage in social movements. Collective action theories offer a variety of causal explanations for why people mobilise for goal-oriented action. The pioneering work of Olson (1965) argues that collective action is impossible when individuals seek self-interest, whilst resource mobilisation theory (MacCarthy and Zald, 1979) cites the lack of financial and personal resources as impediments to collective action.

2.1 *Collective actions on social media*

We identified two main themes in current literature on SM usage for collective action in social movements. The first stream extends the concept of collective action into *connective action*, which reflects that technology, especially SM, offers affordances that changed the diversity of collective actions in social movements (Bennett and Segerberg, 2012). It builds on the idea of “digitally-networked action” for the organisation of dissent (Bennett and Segerberg, 2012, p. 743) contingent on personalised content that drives participation in collective action without the requirement of a collective identity or the organisational resources to focus attention. Vaast *et al.* (2017) added to the concept of connective action by conceptualising SM use at the collective level that is synergistic, meaning that connective action relies upon emerging groups whose requirements are not clearly defined and yet interdependent.

The second theme emphasises the usefulness of SM for the collaborative production of knowledge and attachment of meaning to events, for example, by showing that Facebook can be used to frame or “re-frame” a situation (Lukashina, 2013) or Twitter to focus attention (“keynoting”) (Oh *et al.*, 2015). This theme is consistent with the “social framing” approach (Benford and Snow, 2000), which assumes that shared understandings about reality are required to create and successfully maintain social movements. It should also be noted, however, that also SM platforms through their algorithms are likely to affect the collaborative production of knowledge through influencing information distribution and promotion (termed “echo chambers”) (Cinelli *et al.*, 2021; Kitchens *et al.*, 2020).

2.2 *Implications for mobilisation*

Most empirical evidence suggests that connective actions affect offline CAs, thereby broadly supporting the mobilisation thesis put forward in this study and certainly arguing against digital dualism (Grejdanus *et al.*, 2020). We examined prior social movement studies addressing offline implications of connective actions (see Appendix, Table A1), which support the existence of such mobilisation effects, albeit with mixed insights in terms of linking connective actions with political mobilisation. Besides the general context of each study, the Tables A1–A7 makes note of the orientation of the impact on offline CAs, as being either mobilising or demobilising, as well as the main variables and relationships of interest. Of the eight studies listed, only two studies focussed on protest behaviours (Enjolras *et al.*, 2013; Valenzuela, 2013), whilst the others either more generally considered other domains of activities or political participation activities. A meta-review by Skoric *et al.* (2016), reviewing 15 East Asian studies that were published between 2013 and 2015, concluded that mobilisation effects exist and differ depending on the type of connective actions. Another meta-review supports this view (Boulianne, 2015), whilst at the same time reporting a need for

more clarity about these effects in the context of protest-type activities. Others emphasise that SM usage types amongst other conditions need to be considered (Baek, 2015; Skoric *et al.*, 2016). Expressive use of SM, e.g. engaging in content co-production, seems to play an important role in stimulating political participation including offline activities (Skoric *et al.*, 2016). This insight is consistent with other studies emphasising that heavy SM users, either in terms of usage frequency or expressive use, are more inclined to mobilise for collective action in the physical world (Valenzuela, 2013; Vaccari *et al.*, 2015; Enjolras *et al.*, 2013). Expressive use on SM also seems to be a key to longer-term, cross-domain collective actions given certain conditions (Wilkins *et al.*, 2019).

In contrast to these perspectives, there is also some evidence suggesting that low-threshold connective actions on SM may inhibit or substitute offline CA participation under certain conditions (Morozov, 2011; Wilkins *et al.*, 2019). Low-threshold actions termed as “slacktivist” or “lazy” connective actions, such as liking a comment on Facebook or posting a hashtag on Twitter (Pandey *et al.*, 2019; Schumann and Klein, 2015), may replace offline elements of political participation and consequently may have adverse consequences for groups aiming at achieving a collective purpose. This seems to apply in particular when individuals believe that their online contributions are substantial enough to foster the group’s success (Schumann and Klein, 2015).

To summarise, most of the empirical evidence suggests that connective actions can facilitate other forms of collective actions, in particular those that are offline. However, the conditions and contexts for these likely transitions are important to consider but remain under-researched. There is preliminary evidence suggesting that socio-psychological factors play a role in governing effects of SM use on collective action, e.g. in the context of petitioning (Selander and Jarvenpaa, 2013) or providing expressive support for a shared cause (Nekmat and Ismail, 2019). In particular, implications in terms of further collective actions seem to be sensitive to individual perceptions about the efficacy of the actions taken (Wilkins *et al.*, 2019; Nekmat and Ismail, 2019). Moreover, it was suggested that future studies should account for motives that relate to group enhancement and social identity in the examination of the potential spillover from online to offline engagement (Schumann and Klein, 2015). Therefore, the research gap that we focus on in this study pertains to individual-centric mobilisation which is triggered by engaging in connective actions (i.e. using SM) whilst considering social-psychological factors as mediation variables. We outline in the following section how we conceptualised these mediators and offline CA as our dependent variable.

2.3 Social identity model of collective action (SIMCA)

Synthesising various strands of social psychology literature, Van Zomeren *et al.* (2008) presented an integrated social identity model of collective action (SIMCA), which considers peoples’ subjective sense of *perceived injustice, efficacy and social identity* as the key predictors of collective action. Perceived injustice is seen as a subjective experience of unjust disadvantage, which arises from social comparisons with specific others. However, subjective experiences of group-based relative deprivation have been shown to be more significant than individual perceptions of inequality (Van Zomeren *et al.*, 2008). When group-based inequality is seen as unjust, collective action is amplified by group-based emotions acting as a powerful motivator, such as anger derived from victimisation (Benford, 1997).

Perceived efficacy implies the subjective belief that collective action can result from a sense of collective power to transform a given situation and that such action will lead to expected outcomes (Benford and Snow, 2000; Hunt and Benford, 2004; Gamson, 1992). This view is based on resource mobilisation theory (McCarthy and Zald, 1979) and implies that people need to believe that they possess a sense of control or influence to change a group-related problem (Van Zomeren *et al.*, 2008; Klandermans *et al.*, 2008). It is also consistent with

social cognitive learning theory (Bandura, 1997) in which self-efficacy reflects people's confidence in their ability to successfully conduct a certain behaviour.

Finally, social identity forms a conceptual bridge between the injustice and efficacy perspectives within SIMCA. It is theoretically based on social identity theory, which introduced the concept of a social identity and aims at explaining inter-group relations on the basis of perceived group status differences, perceived legitimacy and stability of such differences and the perceived ability to switch between groups (Tajfel and Turner, 1986; Tajfel, 1978). An individual's social identity may become politicised when the identification is coupled with a political group or entity (such as a social movement organisation). Prior research has proposed that such politicised identities are not only more predictive of collective action than is the more general identification with a disadvantaged group (Stürmer and Simon, 2004), but also more likely to stimulate activism as people engage in power struggles on behalf of their political group (Van Zomeren *et al.*, 2008).

Whilst there is ample support from traditional social movement research for all three socio-psychological conditions leading to higher levels of resonance or mobilising potency of political communication (Benford and Snow, 2000; Gamson, 1992), this study raises the important question of the role connective actions can play as mechanisms potentially affecting these conditions. Consequently, we will next describe and develop in more detail a SIMCA model integrating connective actions in our study's social movement context.

3. Research model development

In this section, we build on the general mobilisation assumption (as outlined in sub-Section 2.2) that connective actions should causally affect participation in offline CAs from the individual perspective. Instead of advocating direct relationships, we consider multiple mediation pathways to participate in offline CA that is potentially triggered by connective actions. The three socio-psychological perspectives offered by SIMCA (Van Zomeren *et al.*, 2008) serve as mediators. In the following sub-section, we first describe connective actions as social learning stimuli. Second, we integrate connective actions into SIMCA as triggers likely to affect the internal socio-psychological state of individuals and consequently a behavioural response in terms of physically engaging in offline CA. Figure 1 presents an overview of our research model.

3.1 Connective action

We first focus on connective actions for interactive socialisation (IS) on SM. From the perspective of social learning theory (Bandura, 1971), learning requires a social context that allows for observation, attention building and reciprocal determinism in the way that the individual and the environment can reciprocally influence each other. On SM, the social context is provided through social interaction, which should become the essential means for improving focus and acquiring a socially constructed understanding of movement events. From a social learning perspective, it does not matter whether such social construction reflects collaborative efforts of people with common goals or opposing perspectives in dialogic interaction. However, it is essential that a social context is provided to focus attention and engage in learning. Whilst arguments or counterarguments can be brought forward by a potentially disparate online community, we believe that they can co-exist with the assumption that often in such interactions social learning applies and reduces differences between people in relation to their understandings of events. Prior information systems research has shown that interaction and dialogic argumentation online generally play important roles for increasing learner's understanding of concepts (Baker, 2003; Harney *et al.*, 2017). Additionally, prior social movement research has emphasised the importance of social

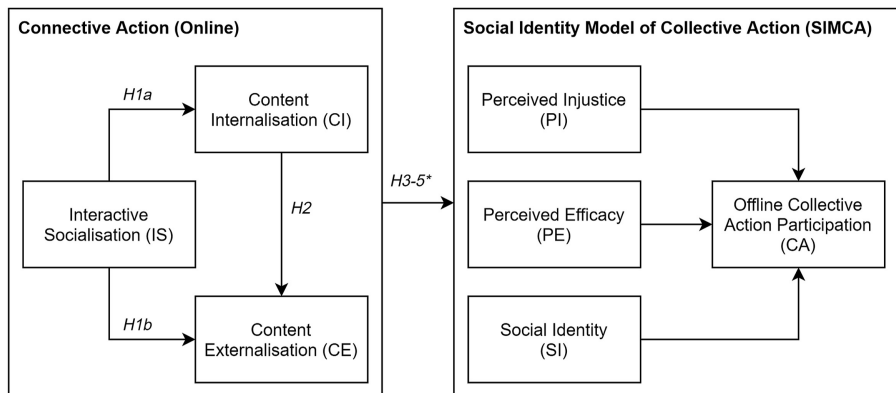

Figure 1.
Theoretical model
(individual-level)

Note(s): *H3-5 are conceptualised as mediation hypotheses assuming that effects from connective actions on offline collective action participation (CA) are governed by three social-psychological variables (PI, PE, SI)

interaction in the physical world as essential for participants to make sense of current social movement events and activities (Snow *et al.*, 2014; Steinberg, 1998) and established social interaction as a requirement for effective collective action to follow (Benford and Snow, 2000; Snow *et al.*, 2014). Since SM have a strong capability for interaction and collaboration (Stamati *et al.*, 2015), it is not surprising that participants in the social movements in Egypt during 2011–2013 also utilised diverse SM to interact and express views and opinions on events (Harindranath *et al.*, 2015). At the same time, such connective actions are likely to foster community building and relationships with other users (Kietzmann *et al.*, 2011) and thus social capital (Huysman and Wulf, 2006), which are all important for gaining focus and, subsequently, for any further internalisation and transfer of insights. Social learning is based around the principles of attention, retention and reproduction (Bandura, 1971). Internalising information builds on attention and requires retention and externalising information involves the reproduction of observed behaviour. In other words, interactive exchanges should help the receiver of information in our social movement context to interpret and translate information (i.e. to internalise content) and stimulate users to share (reproduced) information with others (i.e. to externalise content). Hence, we hypothesise as follows:

H1a–b. Participating in connective actions for interactive socialisation (IS) positively affects participation for (a) content internalisation (CI) and (b) content externalisation (CE).

The level of dependency between such CI and CE of content on SM can be explained by the concept of generalised reciprocity, which usually develops out of a frequent exchange amongst a diverse set of people (Putnam, 2001). The concept is again consistent with social learning theory (Bandura, 1971) as it reflects an ongoing social learning dialogue. A user who has gained something from another (here to understand events, i.e. to internalise content) is likely to be stimulated to give something back (i.e. engage in CE) in return to sustain ongoing supportive exchanges (Hichang *et al.*, 2010). SM provide many differentiated ways to such communal knowledge conversations, which according to a study by Majchrzak *et al.* (2013) in an organisational context could involve meta-voicing, triggered attending, network-informed associating and generative role-taking. Meta-voicing, for example, allows users to add meta-knowledge (feedback, approval, etc.) to the content that is already online and thereby focus the attention on certain perspectives. Linking sharing with consuming was also explained with a

sense of fairness (Wasko and Faraj, 2005) and classified as a relation-based motivation of knowledge sharing in online communities to support social capital (Huysman and Wulf, 2006). We, therefore, assume that users who were consuming content to internalise content should also be more inclined to contribute if they saw others contributing as well. Especially in our social movement context, this exchange is important since it allows for a reciprocal testing of perspectives. It thus satisfies the need to be able to validate the empirical consistency of social frames offered by others (Benford and Snow, 2000). Hence, we propose as follows:

- H2. Participating in connective actions for content internalisation (CI) positively affects participation for content externalisation (CE).

3.2 SIMCA

Next, we consider the role of the internal socio-psychological state of the individual in terms of mediating any effects of connective action on participating in offline CA. For this purpose, we draw on the three socio-psychological predictors of collective action considered in the SIMCA (Van Zomeren *et al.*, 2008). The resulting research model is thus an extension of SIMCA incorporating connective actions as initial stimuli affecting the internal socio-psychological state of the individual.

Regarding *perceived injustice*, social movement scholars have asserted that mobilisation for collective action needs to be supported by an injustice component in communication (Gamson, 1992). In line with this view and relative deprivation theory (Dubé and Guimond, 1986; Crosby, 1982), online community participation should support group-level comparisons and thus increase the awareness of relative group-based deprivation. Structural disadvantages certainly existed in our empirical case (Egypt) and particular incidents were amplified, e.g. the Khaled Said murder highlighting victimisation (Lim, 2012). Again, referring to meta-voicing afforded by SM (Majchrzak *et al.*, 2013), users can easily direct and amplify attention to such unjust incidents, which should be related to their perceived levels of injustice. People thus may connect emotionally without necessarily having a shared common goal (George and Leidner, 2019).

Once subjective perceptions of unjust disadvantages are established, the potential for participating in offline CA to redress the injustice should also increase (Dubé and Guimond, 1986). Group-based emotions like anger based on injustice generally invoke strong action tendencies (Frijda, 1986; Tausch *et al.*, 2011) and have also long regarded as being prefatory to collective action for non-compliance, protest and/or rebellions (Benford and Snow, 2000). In terms of social transformation of societies, the probability for injustice-based emotions to influence collective action was reported to be stronger for incidental than for structural disadvantages (Van Zomeren *et al.*, 2008). Hence, we hypothesise as follows:

- H3. The impact of participating in *connective actions* on participating in offline collective actions (CA) is mediated by *perceived injustice* (PI).

Second, we consider *perceived efficacy*. It theoretically relates to the concept of self-efficacy rooted in Bandura's social cognitive theory (Bandura, 1997), which is an extension of social learning theory (Bandura, 1971). Observation of behaviour is essential. It can be expected that seeing how people like oneself engage in the movement should raise beliefs that one too can engage in similar ways. In our context, taking connective action by internalising information should allow users to cope with the events especially in terms of dealing with threats or addressing fears (e.g. regarding their participation in street protests). In this sense, such connective actions should be linked to an increased understanding of events and the consequences of participating. Once users engage in externalising content, such as self-reportage, certain interpretations of the events are encouraged (Druckman, 2001) and thereby perspectives get amplified or bridged (Snow *et al.*, 2014), which is already a kind of participation that should foster and sustain their own sense of efficacy (Snow *et al.*, 1986).

All these personalised expressions become self-motivating as content is attached to recognition by others on SM, who may repeat this logic and scale up the social network (Segeberg and Bennett, 2011).

From the perspective of resource mobilisation (McCarthy and Zald, 1979) and rational choice (Lichbach, 1996) theories, positive effects of perceived efficacy on the individual decision to participate in collective action can be explained by a value-expectancy component. Collective action under these perspectives requires the individual perception of whether there is an actual possibility to contribute to the movement (Ennis and Schreuer, 1987; Klandermans, 1984; Tausch *et al.*, 2011). The basic assumption in other words is that people engage in collective action if they also believe that their engagement will help to achieve relevant goals (Van Zomeren *et al.*, 2008). Theoretically, this rational calculation motive supports that instrumental reasoning should predict collective action independent of other socio-psychological motives (Klandermans *et al.*, 2008; Stürmer and Simon, 2004). Corroborating the above theoretical arguments, prior experiments suggest that greater participative efficacy beliefs, at least, partially mediated relationships between connective actions and longer-term, cross-domain collective action (Wilkins *et al.*, 2019). Hence, we hypothesise as follows:

H4. The impact of participating in connective actions on participating in offline collective actions (CA) is mediated by *perceived efficacy (PE)*.

The final socio-psychological perspective on collection action is *social identity*. Whilst connective actions do not require a uniform collective identity, they certainly support emerging interdependent groups to engage in a collaborative exchange of information and thereby engage in learning, which fosters a shared understanding of events (Vaast *et al.*, 2017). More specifically, social identity requires perceiving group status differences (Tajfel and Turner, 1986). This should be directly supported by users, e.g. by those engaged in “keynoting” (Oh *et al.*, 2015) or commenting on events (Lukashina, 2013) to emphasise different views of events. In terms of mass-updating, we see support from “frame bridging”, i.e. linking ideologically congruent but prior unconnected views regarding a particular issue or problem (Snow *et al.*, 1986), which allows for an immediate tapping into a large group of ideologically congruent users across the world and thereby question the legitimacy or stability of perceived group status differences.

According to SIMCA, once members of a disadvantaged group perceive the inter-group status differential to be illegitimate and unstable, they are more likely to identify with their group and participate in collective action to improve the inter-group status differential (Van Zomeren *et al.*, 2008; Ellemers *et al.*, 1999; Tajfel and Turner, 1986). Thus, SIMCA includes the core assumption that the level of identification with the disadvantaged group should be an important predictor of collective action. As outlined above, the increase in shared definitions of situations through connective actions should foster this important level of identification with the disadvantaged group, which, in turn, is likely to increase participation in collective action, especially on the grounds of perceived empowerment (Reicher *et al.*, 2010; Drury *et al.*, 2020). However, whilst social identity is, therefore, understood as tied to collective action, the nature of that identity and of collective action also seems to play an important role in determining this relationship (Drury and Reicher, 2000). Consequently, different models have been proposed in prior literature to represent social identity with different dimensions (e.g. Ellemers *et al.*, 1999). In our context, affective and value-based dimensions should be most applicable as, whilst not identical, they are most consistent with the injustice and efficacy arguments given above. Hence, we hypothesise as follows:

H5. The impact of participating in connective actions on participating in offline collective actions (CA) is mediated by *social identity (SI)*.

4. Research methodology

4.1 Data collection

The survey targeted students from three major universities in Cairo (Egypt) (see Table 1). We considered students as a valid target population for this research project. They are seen worldwide not only as a potent force of politically and technically engaged activists (Calenda and Mosca, 2007; Altbach and Klemencic, 2014), but can also be motivated via SM to engage in collective action (Enjolras *et al.*, 2013). This in particular holds for states in the Middle East and North Africa (MENA) region, where between 22.1% (Jordan) and 54.7% (Yemen) of students between the years 2003–2007 participated in offline political activities, in particular joining protests for a range of economic and political grievances despite potential risks when voicing dissent (Shafiq *et al.*, 2014). It has also been well documented that students played important roles as activists or tech-savvy contributors, in particular in our study's context of Egypt's social movements (Hussain and Howard, 2013; Howard *et al.*, 2011). Also in relation to Egypt (Tufekci and Wilson, 2012), protestors on the Tahrir Square in Cairo in 2011 had an average age of just under 29 years skewed to the youthful side with a median age of 26 years. The majority was well educated with over 70% having earned an undergraduate or postgraduate degree.

We implemented a mixed-mode survey using online and hardcopy questionnaires to improve survey response (Dillman *et al.*, 2009) and offered no incentives. We targeted the whole available population of students and thereby directly invited 1,710 undergraduate students to complete the questionnaire over a period of about 4 weeks immediately after the second uprising of 2013 (also dubbed as the people's impeachment), promising anonymous treatment and academic use only. The hardcopy versions of the questionnaire were distributed in class to all attending students. Table A2 in the Appendix gives an overview of the populations and acquired samples. We recorded a gross response rate of 21%, which included 364 returns (201 full and 163 partial survey responses). After eliminating the partial data sets (online and hardcopy returns) and 7 invalid full responses (hardcopy returns only) due to aberrant response behaviour, we retained 194 useable data sets for data analysis, which corresponds to a net response rate of 11%. We conducted several rounds of pre-tests, where the consistency and understandability of the questionnaire were assessed by selected target persons in Egypt, our local co-author and the research assistant in Egypt for content validity. In particular, statements sensitive to the ongoing dynamics in Egypt were rephrased, and the structure and

University				<i>N</i>	%
The American University in Cairo (AUC)				75	38.7
German University in Cairo (GUC)				64	33.0
Ain Shams University (ASU)				55	28.4

Gender	<i>N</i>	%	Status	<i>N</i>	%
Female	127	65.5	Full-time	179	93.2
Male	67	34.5	Part-time	13	6.8
Missing	0		Missing	2	

	<i>N</i> (missing)	Mean	Std Dev
Daily SM use during the 2011 revolutionary events ^a	188 (6)	5.31	1.67
Daily SM use during the 2013 revolutionary events ^a	187 (7)	5.49	1.54
Actual street protest participation (since 2011) ^b	194 (0)	4.30	2.05

Note(s): ^aAssessed on a scale between “never” (1) and “many times per day” (7)

^bAssessed on a scale between “Strongly disagree” (1) and “Strongly agree” (7)

Table 1.
Characteristics of the
survey
sample (*N* = 194)

flow of questions improved. As control variables, we included the single-item measures age, gender and perceived usefulness (PU) of Facebook, YouTube and Twitter.

4.2 Data analysis

First, we estimated a path model using PLS structural equation modelling (PLS-SEM) (Lohmöller, 1989; Wold, 1982), which was used because of its resistance to violations of normality and acceptance of reflectively and formatively measured latent variables. Other important reasons included its efficiency (converges quickly) and good level of support for predictive and exploratory purposes. Second, a mediation analysis according to current guidelines (Hair *et al.*, 2016) was applied to test indirect effects on participating in collective action. For PLS-SEM analysis, we used the software *SmartPLS 3* (Ringle *et al.*, 2015).

4.3 Measurement model

The Appendix (Tables A3 and A4) lists the definitions of the model constructs and their operationalisations. In terms of connections actions, we considered *IS*, *CI* and *CE* as formatively measured latent constructs taken from a related qualitative SM study in the same movement context (Harindranath *et al.*, 2015). *IS* includes engaging in interactive communication and discussions, and portraying to others own thoughts and opinions. *CI* relates to validating and complementing information offered by various sources including different media and opinions of others, often instantly and continuously. *CE* includes circulating self-selected or self-produced content. The underlying measures of each construct are not expected to have co-variation within the main construct – and cause rather than are caused by their latent construct – and need not necessarily be correlated. The other constructs constitute reflectively measured *perceived efficacy*, *perceived injustice*, *social identity* and (*offline*) *collective action participation*. For *perceived efficacy*, we reverted to a version of self-efficacy (Bandura, 1997), which was contextualised to capture a respondent's sense of being able to contribute as an individual to the movement (Ennis and Schreuer, 1987). In this sense, we focussed our operationalisation on individual efficacy rather than group efficacy, which was reported to relate less to individual participation decisions for collective action (Klandermans *et al.*, 2008). In terms of *perceived injustice*, we focussed on generally capturing inequality and relative deprivation related to treatment, rights and resources (Dubé and Guimond, 1986; Van Zomeren *et al.*, 2008). For *social identity*, we refer to the commonly cited definition by Tajfel (1978, p. 63), which maintains at the theoretical level that social identity is “[. . .] that part of an individual's self-concept which derives from his knowledge of his membership of a social group (or groups) together with the value and emotional significance attached to that membership”. Consistent with this definition, we included aspects of self-categorisation (by asking about being part of the group), group self-esteem (by considering if the respondent likes to be a member and also let others know about his group membership) and affective commitment (in relation to respect for the group) in a combined operationalisation. Whilst different facets of social identity could also be measured separately, they usually show high co-variation and are often considered as a unidimensional construct (Van Zomeren *et al.*, 2008; Ellemers *et al.*, 1999). As there was no unifying central governing entity (such as a social movement organisation) in the context of our study, which could serve as an anchor for assessing political identity, we related the assessment to the non-politicised online social network that was interacting and exchanging insights on movement events. Whilst this operationalisation is consistent with the assumption of an emergent and decentralised leadership characterising connective actions (Azer *et al.*, 2019), it also means that we did not assess politicised or activist identities. Our operationalisation of *offline CA* combines both specific and general action propensities (Van Zomeren *et al.*, 2008). We restricted our perspective to collective activities that were aimed at improving the conditions of the Egyptian society seen as a whole in the context of the movement rather than assessing certain inter-group

differentiations. All three reflectively measured constructs were adapted from previous studies with well-established psychometric properties.

5. Data analysis

5.1 Survey sample properties

The collected data represents mainly young undergraduate students aged between 18 and 40 years with a mean age of 20.5 years, who are about equally distributed across the three target universities (see Table 1). The data suggest that respondents were in general highly active movement participants in both the online and offline worlds. In terms of connective actions, high levels of daily SM use (means) with low variations (standard deviations) were reported in relation to Egypt's social movements of 2011 and 2013. There was also a substantial level of actual participation in street protests, albeit on a lower level (mean) and with an increased variation (standard deviation). Only 13% of the students reported no participation ("strongly disagree") in street protests. The retained data set for PLS-SEM includes 194 responses and exhibits extremely low levels of missing data. In relation to the indicators considered in the developed research model, the number of missing values range from 0 to 4 (2%). We, therefore, used the mean value replacement approach in the PLS-SEM estimation, which is recommended in situations when there are less than 5% values missing per variable (Hair *et al.*, 2016).

5.2 Bias analysis

To examine the possibility of survey *nonresponse bias*, we used the commonly applied wave analysis (Van der Stede *et al.*, 2006). For this purpose, we used a split-sample approach, where one sub-sample represented early respondents and the other represented late respondents according to the response time and the data collected with the online survey. To integrate responses across different universities, which were not invited concurrently, we calculated response times relative to the fastest respondent of each sub-sample. As the comparison between those two groups revealed no significantly different characteristics in terms of gender (χ^2 test, $p = 0.22$), enrolment status (χ^2 test, $p = 0.29$), mean age (two-sample unpaired t -test, $p = 0.22$) and mean PU of SM in general (two-sample unpaired t -test, $p = 0.24$), we see no evidence for survey nonresponse bias.

Next, we were interested to understand potential *distribution mode bias* in relation to the same variables. The analysis revealed that the online mode allowed significantly more female students (χ^2 test, $p = 0.04$) and part-time students (χ^2 test, $p = 0.00$) to respond. In terms of the latter, the explanation is that part-time students were underrepresented in the classes through which we distributed the hardcopy version. We did not see any significant differences in terms of mean age and mean PU of SM in general (two-sample unpaired t tests). We conclude that self-selection bias was most likely introduced through the online administration of the survey in terms of gender and enrolment status. Since the online returns only account for 1/3 of our data sets (see Table A2 in the Appendix) and the proportion of part-time students is generally low, the reliability of our results, however, should not be a major concern in this regard.

As the survey is based on a mono-method research design and a self-report instrument, we needed to test for *common method variance* (CMV) (Malhotra *et al.*, 2006). We conducted three diagnostic techniques to test for CMV. First, we applied the Harman's single-factor test (Podsakoff *et al.*, 2003). The results showed that the largest single component could not explain most of the variance in our data (accounting for 30.9%). Instead, we found that our data consisted of, at least, six components with eigenvalues >1 and that these components collectively explained 68.5% of the total variance. This suggests that whilst there is likely to be

some CMV, the effect is relatively small. Second, we examined a correlation matrix of the constructs to determine if any of the correlation coefficients (Pearson) were above 0.9 for the formative indicators. If there were correlations above this threshold, this would have provided evidence that CMV existed (Lowry and Gaskin, 2014). In our case, all correlations were smaller, thus indicating that the probability of CMV is low. Third, we included a single-item exogenous measure (age) connected to every endogenous latent variable in the structural model as a theoretically unrelated marker variable (Nitzl, 2016; Lindell and Whitney, 2001). A comparison of the estimated path model relationships with and without this additional marker variable showed no notable differences. All theorised pathways maintained their levels of significance. Thus, neither of the applied tests suggests a threat of CMV.

5.3 Measurement model validation

We now turn our attention to separate reliability and validity tests (measures are given in the Tables A1–A7) of the latent variables (Hair *et al.*, 2016; Petter *et al.*, 2007). For the assessment of our *reflective measurement model*, we first evaluated internal consistency reliability by reviewing the composite reliability values instead of Cronbach's alpha due to its limitations (Hair *et al.*, 2016). The values of all four reflective constructs values are well above 0.70 and thus indicate high levels of internal consistency (Nunnally and Bernstein, 1994). They are also well below 0.95, which indicates no problematic use of redundant items (Hair *et al.*, 2016). Next, we considered convergent validity by considering the outer loadings of the indicators and the average variance extracted (AVE). The outer loadings of all indicators are statistically significant ($p < 0.001$) and are above 0.70 and are thus deemed acceptable (Hair *et al.*, 2016). Convergent validity is also supported for all constructs considering the AVE values, which are above the suggested minimum level (>0.50). In addition, the square roots of the AVE values are all higher than 0.70. Finally, we established discriminant validity through three ways. First, with regard to the Fornell–Larcker criterion (Fornell and Larcker, 1981), we confirm that the square root of the AVE of each reflective construct is higher than the construct's highest correlation with any other construct. Second, in terms of cross-loadings, we confirm that each indicator has the highest value for the loading with its own construct, whilst their cross-loadings with other constructs are considerably lower. Third, the heterotrait-monotrait ratio (HTMT) of the correlations was applied measuring what the true correlation between constructs would be if they were perfectly measured. All yielded HTMT values are well below the conservative threshold value of 0.85 and no confidence interval of the HTMT statistic (derived by bootstrapping) includes the value of 1 for all combination of constructs (Hair *et al.*, 2016). As the standardised item loadings on their own constructs are all greater than 0.7, we also report that indicator reliability is acceptable.

Formatively measured constructs, including our three modes of connective actions to account for interactive socialisation (IS), content internalisation (CI), and content externalisation (CE), require different validation approaches (Hair *et al.*, 2016). For content validity, we established that major facets of the contextualised constructs were captured by consulting qualitative theory building research in the same social movement context (Harindranath *et al.*, 2015). In terms of empirically assessing the formative constructs, we calculated a range of values (see Table A7) and again relied on bootstrapping (5,000 subsamples) to test the statistical significance of the results using *t*-tests. We find that the weights of all formative indicators are significant ($p < 0.05$) except two (CI1 and CI2), which are marginally significant ($p < 0.1$) in which case it is advised to investigate outer loadings. The outer loadings of both marginally significant indicators are high (0.76 and 0.79, i.e. >0.5) and their *t*-values (not in Table A7) indicate very high significance ($p < 0.001$), which are both conditions suggesting to keep the indicators (Hair *et al.*, 2016). Since prior qualitative research also provides theoretical support (Harindranath *et al.*, 2015), we retained both indicators in the

model to preserve content validity (Hair *et al.*, 2016). Additionally, we observed no problematic levels of multi-collinearity amongst the formative indicators for all constructs (variance inflation factor (VIF) < 3).

5.4 Structural model and multiple mediation tests

The purpose of the SEM was to test the research hypotheses for which we used a range of different measures (Hair *et al.*, 2016). The PLS-SEM results shown in Figure 2 include the standardised path coefficients and, significance of the pathways based on a two-tailed *t*-test, the amounts of variance explained (adjusted R^2), which range between 0.12 and 0.53. Collective action participation has an adjusted R^2 value of 0.21. Please note that we reported the adjusted R^2 values. Considering model complexity and sample size has adjusted the R^2 values downward. As a guideline, R^2 values below 0.19, 0.33 and 0.67, or above 0.67 can be considered very weak, weak, moderate and substantial (Chin, 1998), respectively. Again, we used the results from bootstrapping with 5,000 sub-samples to calculate *t*-statistics and standard errors.

We first turn to hypotheses H1(a–b) and H2, which are both supported by our analysis. IS directly affects CI ($\beta = 0.64, p < 0.001$ and $f^2 = 0.69$) and CE ($\beta = 0.56, p < 0.001$ and $f^2 = 0.39$), thus supporting H1(a–b). Effect sizes show that the positive impact on the former is large and the latter medium (Cohen, 1988). In support of H2, CI has a positive direct impact on CE ($\beta = 0.24, p < 0.01$ and $f^2 = 0.07$).

Next, we turn our attention to multiple mediation analyses (Nitzl *et al.*, 2016) to investigate the indirect effects of the three modes of connective actions (IS, CI and CE) on offline CA and test our mediation research hypotheses (H3–5) based on bootstrapping the indirect effects. This approach yields higher statistical power compared with the Sobel test, which was traditionally applied in prior research (Hair *et al.*, 2016). It is also worth noting that we considered all mediators simultaneously in the model, which allows gaining the required complete picture on pathways to offline CA and controlling for all other considered mediators when investigating a given mediator. Table 2 includes all detected significant indirect effects; the parameter estimates and their significance levels and bias corrected confidence intervals. Since we essentially draw on these bootstrap confidence intervals for significance testing, it is important to note that neither includes zero. Thus, based on this analysis, engaging in any form of connective action leads to significant *total indirect effects* on offline CA and the following specific indirect effects: IS triggers four pathways (1, 3, 4 and 7), CE and CI are each triggering two pathways (2 and 6 and 5 and 6, respectively) to offline connective action. The analysis of our research hypotheses yields more nuanced findings from the perspective of socio-psychological mediators.

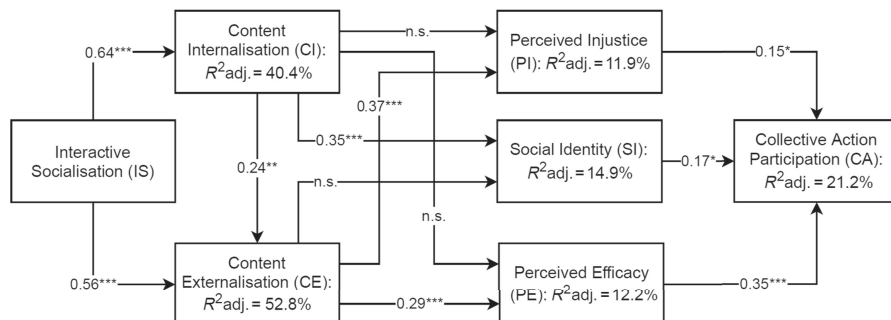

Note(s): * $p < 0.05$; ** $p < 0.01$; *** $p < 0.001$; n.s. not significant
Control variables are not depicted for simplicity

Figure 2. Results of the structural model

	Effects (β)	95% confidence interval (bias corrected)
Total indirect effects of connective action on offline collective action		
IS \rightarrow CA	0.180***	[0.094, 0.261]
CI \rightarrow CA	0.133*	[0.036, 0.237]
CE \rightarrow CA	0.172***	[0.079, 0.269]
Specific indirect effects of connective action on offline collective action		
<i>Social-psychological mediator: perceived injustice (H3)</i>		
1: IS \rightarrow CE \rightarrow PI \rightarrow CA	0.031 ^c	[0.003, 0.071]
2: CE \rightarrow PI \rightarrow CA	0.055 ^c	[0.006, 0.120]
<i>Social-psychological mediator: perceived efficacy (H4)</i>		
3: IS \rightarrow CE \rightarrow PE \rightarrow CA	0.058*	[0.019, 0.112]
4: IS \rightarrow CI \rightarrow CE \rightarrow PE \rightarrow CA	0.016*	[0.005, 0.037]
5: CI \rightarrow CE \rightarrow PE \rightarrow CA	0.025*	[0.008, 0.085]
6: CE \rightarrow PE \rightarrow CA	0.104**	[0.036, 0.186]
<i>Social-psychological mediator: social identity (H5)</i>		
7: IS \rightarrow CI \rightarrow SI \rightarrow CA	0.037*	[0.008, 0.085]
8: CI \rightarrow SI \rightarrow CA	0.058*	[0.013, 0.126]

Table 2. Causal chains affecting offline collective action

Note(s): IS = interactive socialisation, CE = content externalisation, CI = content internalisation, PE = perceived efficacy, PI = perceived injustice, SI = social identity and CA = offline collective action
^c $p < 0.1$, * $p < 0.05$, ** $p < 0.01$, *** $p < 0.001$ and two-tailed test

We first consider the role of perceived injustice as mediator (H3), which only governs effects from connective actions on two marginally significant pathways (1–2: $p < 0.1$), both involving indirect effects from CE. Effects from CI are not mediated by perceived injustice. H3 is thus partially supported. In terms of perceived efficacy, we see a much more pronounced mediation role as it mediates indirect effects initiated by all three modes of connective action (pathways 3–6: at least, $p < 0.05$). H4 is thus supported. Finally, whilst social identity mediates indirect effects originating from two forms of connective action, it does not in terms of CE (pathways 7–8: $p < 0.05$). H5 is thus partially supported. Rerunning the estimation of the structural model with additional direct relationships between connective actions and offline CA confirmed that there are no significant direct effects. We thus conclude that all mediation effects reported above constitute full mediation.

5.5 Post hoc analyses

We ran additional analyses to investigate (1) possible interaction effects between the socio-psychological predictors considered in our research model and (2) test direct effects of social identity on perceived injustice and perceived efficacy, which were suggested in the original SIMCA model (Van Zomeren *et al.*, 2008). In terms of the former, based on the product indicator approach with standardised product terms (Hair *et al.*, 2016), we detected no significant interaction effects. In terms of the latter, we also detected no significant effects when adding these two relationships to our model in our PLS-SEM approach.

6. Discussion and implications

The objective of this study was to test associations between different modes of connective actions with participating in offline CAs from the individual level of analysis considering socio-psychological indicators as conditions drawn from the SIMCA (Van Zomeren *et al.*, 2008). There is limited research providing an integrated analysis of online and offline

participation in social movements (for an exception, based on experiments, see: [Schumann and Klein, 2015](#)). Our central assumption was to test spillover effects from online to offline engagement in terms of individual participation in offline CAs without the involvement of a unifying social movement organisation. The results from this study, at least, partially support all five research hypotheses and include several key findings in relation to significant mediation pathways originating from different modes of connective action by SM users. Rational calculation (perceived efficacy) seems to be most important in terms of governing effects in comparison with perceptions of unjust disadvantages and social identity. We now discuss our main findings in more detail.

First, we argued by building on social learning theory ([Bandura, 1971](#)) that online social interaction should provide the initial learning context to focus attention and subsequently engage in online social framing processes to make sense and help others make sense of dynamically changing events ([Snow et al., 2014](#); [Steinberg, 1998](#)). Indeed, we can confirm that connective actions based on IS on SM provide an important momentum for other forms of connective actions, i.e. for both CI and CE ([H1a–b accepted](#)). Externalisation, however, is also driven by internalisation ([H2 accepted](#)). Again considering social learning theory ([Bandura, 1971](#)), seeing that others have contributed (observation) motivates users to inform others as well (reproduction), thereby satisfying general reciprocity in knowledge exchanges ([Putnam, 2001](#)). These findings offer a more nuanced differentiation of interrelated connective actions in comparison with the original concept describing a synergetic “mass-production” of personalised content ([Bennett and Segerberg, 2012](#)).

Next, we integrated connective actions with SIMCA ([Van Zomeren et al., 2008](#)) to investigate under which socio-psychological conditions connective actions translate into offline CAs from an individual level of analysis. Prior research has insufficiently covered offline implications of specific connective actions. In support of our mobilisation assumption, our findings show that each considered mode of connective action provides positive total indirect effects on participating in offline CA through the mediation pathways considered. We thus demonstrate that connective actions can also extend into offline collective actions, given that socio-psychological conditions in accordance with SIMCA ([Van Zomeren et al., 2008](#)). Thus, in our context, demobilising effects (“slacktivism”) were not observed ([Schumann and Klein, 2015](#); [Morozov, 2011](#); [Wilkins et al., 2019](#)). However, when considering the specific indirect effects, it becomes apparent that certain combinations (pathways) are required to stimulate participation in offline connective actions. Social interactivity builds on both CE and CI and utilises all three socio-psychological factors as full mediators (on pathways 1, 3, 4 and 7). CE and CI, however, seem to require different socio-psychological mediators to affect offline CA. CE builds mainly on perceived efficacy (pathways 3–6) and to lesser extent on perceived injustice in terms of indirectly affecting offline CA participation (pathways 1 and 2). CI relies only on social identity for the same purpose (pathways 7–8).

Accordingly, we report that efficacy perceptions ([Wilkins et al., 2019](#)) and thereby rational calculation on so-called “instrumental pathways” to collective action ([Klandermans et al., 2008](#)) can be important requirements for connective actions to stimulate offline collections actions within the same movement context. It is important to note that they are mostly linked with CE. We thus add to prior studies on the importance of expressive ([Vaccari et al., 2015](#)) and heavy use of SM ([Enjolras et al., 2013](#)) for stimulating further collective actions. Theoretically, this special role of CE is consistent with the postulated “sender” effect seen in general political communication ([Pingree, 2007](#)). Externalising re-produced information through connective action affects the externalising user more than the receiving user, at least, when considering efficacy perceptions and subsequent levels of participation in offline CAs. This finding also challenges the assumption of Olson’s original theory of collective action ([Olson, 1965](#)) about weak individual commitment in large groups (free riding). Whilst we know that free-riding does not equally apply to connective actions under conditions of radically reduced communication

costs (Bennett and Segerberg, 2012), our results support the view that once erstwhile free-riders have been turned into active online contributors, they are also more likely to engage in offline CAs governed by increased efficacy perceptions. However, consuming only personalised content through connective actions also seems to positively translate into offline CAs but under the condition of an increased social identity. By identifying with other users (as members of a disadvantaged group) through CI, users seem to develop a stronger inner obligation to participate also offline. This finding is consistent with social identity theory suggesting that it is the extent to which people identify with a particular social group that determines their inclination to act in terms of their group membership (Tajfel and Turner, 1986). Extending Stürmer and Simon (2004), we thus also see evidence for two main yet complementary causal chains to offline CA originating from connective actions. One which is instrumental, calculated and reward driven (through efficacy perceptions based on CE), and the other which is more driven by obligation (to enact a collective identity supported by CI). In comparison, the importance of perceived injustice as mediator is less convincing as associated indirect effects are only marginally significant. As our *post hoc* analysis did not reveal any interaction effects between the socio-psychological mediators, the identified pathways seem to be additive rather than interactive in terms of affecting offline CAs.

Finally, we provide evidence supporting the view that social movements can emerge based on the social learning logic of IS leading to a co-production and co-distribution of personalised expressions capturing individual perspectives on events (Snow *et al.*, 2014; Steinberg, 1998). In our context, these mechanisms do not seem to necessarily require a central social movement organisation to control and administer contributions, which is a traditional assumption for social movement success based on resource mobilisation theory (Hensmans, 2003; McCarthy and Zald, 1979). Instead, the idea that “digitally-networked action” works for the organisation of dissent (Bennett and Segerberg, 2012, p. 743) in the same movement context is in our view contingent on not only personalised, but especially mass-produced expressive (externalised) political content that conveys collective power (efficacy) without the need for a central governing organisation. Our observations in terms of connective actions and implications for offline CAs, however, are likely to require that motivated users can operate on sufficiently open SM platforms to interactively discuss and ultimately share personalised views, which is not much different from the offline world.

6.1 Limitations and future work

Our results relate to social movements in Egypt during 2011–2013 and are therefore contingent on the given time- and case-specific socio-political context and changing conditions. Future studies could therefore consider the role of different political or technical contexts, which are likely to inhibit online and offline political participation, e.g. repressive regimes in connection with state surveillance or security and privacy issues. The reported importance of (political) CE calls for the development of a more nuanced conceptualisation of online political expression in conjunction with suitable measures. Since this study investigates the seamless use of Twitter, Facebook and YouTube used for online connective action, future research could also focus on untangling the roles of these or other specific platforms for connective action. In addition, online social interactions can exhibit interpersonal influence dynamics at the micro-level, which can result in social polarisation or patterns of opinion diversity observable at higher levels of analysis. Whilst such an analysis was outside the scope of this study, we consider it a promising alternative avenue for future research aiming at explaining contemporary forms of collective action.

Finally, we note that common problems in empirical research are reliability and validity, which can only be safeguarded and not guaranteed. Whilst we followed current guidelines to ensure satisfactory levels of reliability, we could not apply random sampling based on

predefined target groups as no central student databases existed for any of the universities in Egypt. Instead, we contacted all undergraduate students from the three participating universities. It is also worth noting that whilst students certainly played an important role in advancing the movement, our sample may not represent all characteristics of the wider citizen population equally well, especially in terms of risk-taking and technical engagement. Additionally, we needed to rely on mixing of survey modes to improve response rates. The level of introduced bias should be of no major concern for our study since previous research indicated that hardcopy and web respondents respond similarly (Dillman *et al.*, 2009). However, the online mode of survey administration seems to have positively affected responses rates from female and part-time students and therefore introduced self-selection bias. In terms of measurement items, we had to restrict ourselves to a manageable set of measures perceived to fit our research model. It should be noted that many core constructs could be adopted or extended to cover aspects, which may be more applicable in different empirical contexts.

7. Conclusion

Whilst the extant literature has established the role of SM for connective action reflecting interconnection and personal communication in support of social movements, disentangling specific causal patterns linking connective actions with participating in offline CA has remained under-researched. Drawing on primary quantitative data within the context of a social movement in a developing economy (Egypt) at the time of our empirical inquiry, we developed and tested likely pathways to offline CA in a nomological framework, integrating connective actions (Bennett and Segerberg, 2012) into SIMCA (Van Zomeren *et al.*, 2008). We have provided evidence that the emergence of a social movement is supported by connective actions, allowing for synergetic and reciprocal social learning stimuli, which affect classic socio-psychological mechanisms and eventually steer participation in collective action from the individual perspective. Extending Stürmer and Simon (2004), our findings mainly support a duality of pathways: First, instrumental pathways governed by increased efficacy perceptions and pathways more driven by an internal obligation operating on a collective identity. In addition, both sets of pathways benefit from IS directly supporting both CI and CE. Our findings have important implications for theory. We add to prior literature on offline implications of connective actions, which we have embedded into an interactive social learning context utilising a mass production of personal expressions of “ordinary” social movement participants. We emphasise that rational choice considerations, a key tenet of traditional resource mobilisation theory, still apply when reviewing the role of connective action for offline CA in contemporary social movements. To the best of our knowledge, we thus provide a novel account of a social movement grounded in primary data on how SM use is likely to translate to collective action participation in the physical world.

References

- Agarwal, N., Lim, M. and Wigand, R. (2012), “Raising and rising voices in social media”, *Business and Information Systems Engineering*, Vol. 4 No. 3, pp. 113-126.
- Altbach, P.G. and Klemencic, M. (2014), “Student activism remains a potent force worldwide”, *International Higher Education*, No. 76, pp. 2-3.
- Azer, E., Harindranath, G. and Zheng, Y. (2019), “Revisiting leadership in information and communication technology (ICT)-enabled activism: a study of Egypt’s grassroots human rights groups”, *New Media and Society*, Vol. 21 No. 5, pp. 1141-1169.
- Baek, Y.M. (2015), “Political mobilization through social network sites: the mobilizing power of political messages received from SNS friends”, *Computers in Human Behavior*, Vol. 44, pp. 12-19.

- Baker, M. (2003), "Computer-mediated argumentative interactions for the co-elaboration of scientific notions", *Arguing to Learn*, Springer, pp. 47-78.
- Bandura, A. (1971), *Social Learning Theory*, Prentice-Hall, Englewood Cliffs, NJ.
- Bandura, A. (1997), *Self-efficacy: The Exercise of Control*, W. H. Freeman and Co., New York.
- Benford, R.D. (1997), "An insider's critique of the social movement framing perspective", *Sociological Inquiry*, Vol. 67 No. 4, pp. 409-430.
- Benford, R.D. and Snow, D.A. (2000), "Framing processes and social movements: an overview and assessment", *Annual Review of Sociology*, Vol. 26, pp. 611-639.
- Bennett, W.L. and Segerberg, A. (2012), "The logic of connective action: digital media and the personalization of contentious politics", *Information, Communication and Society*, Vol. 15 No. 5, pp. 739-768.
- Bernroider, E.W.N., Harindranath, G. and Kamel, S.H. (2016), "A comparative analysis of social media platforms and the effects of the internet cut-off for Egypt's social transformation movements", *Conf-IRM*, Cape Town, SA, pp. 1-12.
- Borrero, J.D., Díaz Andrade, A. and Urquhart, C. (2013), "Social movements on the internet: together alone or alone together?", *ECIS*, Utrecht, NL, p. 15.
- Boulianne, S. (2015), "Social media use and participation: a meta-analysis of current research", *Information, Communication and Society*, Vol. 18 No. 5, pp. 524-538.
- Calenda, D. and Mosca, L. (2007), "The political use of the internet: some insights from two surveys of Italian students", *Information, Community and Society*, Vol. 10 No. 1, pp. 29-47.
- Castells, M. (2004), *The Power of Identity*, Blackwell, Oxford/Malden.
- Chin, W.W. (1998), "The partial least squares approach to structural equation modeling", in Marcoulides, G.A. (Ed.), *Modern Methods for Business Research*, Lawrence Erlbaum Associates, NJ, pp. 295-334.
- Cinelli, M., Morales, G.D.F., Galeazzi, A., Quattrociochi, W. and Starnini, M. (2021), "The echo chamber effect on social media", *Proceedings of the National Academy of Sciences*, Vol. 118 No. 9, pp. 1-8.
- Cohen, J. (1988), *Statistical Power Analysis for the Behavioral Sciences*, Lawrence Erlbaum Associates, Hillsdale, NJ.
- Crosby, F.J. (1982), *Relative Deprivation and Working Women*, Oxford University Press, New York.
- Dillman, D.A., Phelps, G., Tortora, R., Swift, K., Kohrell, J., Berck, J. and Messer, B.L. (2009), "Response rate and measurement differences in mixed-mode surveys using mail, telephone, interactive voice response (IVR) and the Internet", *Social Science Research*, Vol. 38 No. 1, pp. 1-18.
- Druckman, J.N. (2001), "The implications of framing effects for citizen competence", *Political Behavior*, Vol. 23 No. 3, pp. 225-256.
- Drury, J. and Reicher, S. (2000), "Collective action and psychological change: the emergence of new social identities", *British Journal of Social Psychology*, Vol. 39 No. 4, pp. 579-604.
- Drury, J., Stott, C., Ball, R., Reicher, S., Neville, F., Bell, L., Biddlestone, M., Choudhury, S., Lovell, M. and Ryan, C. (2020), "A social identity model of riot diffusion: from injustice to empowerment in the 2011 London riots", *European Journal of Social Psychology*, Vol. 50 No. 3, pp. 646-661.
- Dubé, L. and Guimond, S. (1986), "Relative deprivation and social protest: the personal-group issue", *Relative Deprivation and Social Comparison: The Ontario Symposium*, Erlbaum, Hillsdale, pp. 201-216.
- Ellemers, N., Kortekaas, P. and Ouwerkerk, J.W. (1999), "Self-categorisation, commitment to the group and group self-esteem as related but distinct aspects of social identity", *European Journal of Social Psychology*, Vol. 29 Nos 2-3, pp. 371-389.
- Enjolras, B., Steen-Johnsen, K. and Wollebæk, D. (2013), "Social media and mobilization to offline demonstrations: transcending participatory divides?", *New Media and Society*, Vol. 15 No. 6, pp. 890-908.

- Ennis, J.G. and Schreuer, R. (1987), "Mobilizing weak support for social movements: the role of grievance, efficacy, and cost", *Social Forces*, Vol. 66 No. 2, pp. 390-409.
- Fornell, C. and Larcker, D.F. (1981), "Evaluating structural equation models with unobservable variables and measurement error", *Journal of Marketing Research*, Vol. 18 No. 3, pp. 39-50.
- Frijda, N.H. (1986), *The Emotions*, Cambridge University Press, Cambridge.
- Gamson, W.A. (1992), *Talking Politics*, Cambridge University Press, New York.
- George, J.J. and Leidner, D.E. (2019), "From clicktivism to hacktivism: understanding digital activism", *Information and Organization*, Vol. 29 No. 3, p. 100249.
- Greijdanus, H., de Matos Fernandes, C.A., Turner-Zwinkels, F., Honari, A., Roos, C.A., Rosenbusch, H. and Postmes, T. (2020), "The psychology of online activism and social movements: relations between online and offline collective action", *Current Opinion in Psychology*, Vol. 35, pp. 49-54.
- Hair, J.F., Hult, G.T.M., Ringle, C.M. and Sarstedt, M. (2016), *A Primer on Partial Least Squares Structural Equation Modeling (Pls-sem)*, Sage, Los Angeles.
- Harindranath, G., Bernroider, E.W.N. and Kamel, S. (2015), "Social media and social transformation movements: the role of affordances and platforms", *ECIS*, Muenster.
- Harney, O.M., Hogan, M.J. and Quinn, S. (2017), "Investigating the effects of peer to peer prompts on collaborative argumentation, consensus and perceived efficacy in collaborative learning", *International Journal of Computer-Supported Collaborative Learning*, Vol. 12 No. 3, pp. 307-336.
- Hensmans, M. (2003), "Social movement organizations: a metaphor for strategic actors in institutional fields", *Organization Studies*, Vol. 24 No. 3, pp. 355-381.
- Hichang, C., MeiHui, C. and Siyoung, C. (2010), "Testing an integrative theoretical model of knowledge-sharing behavior in the context of Wikipedia", *Journal of the American Society for Information Science and Technology*, Vol. 61 No. 6, pp. 1198-1212.
- Howard, P.N., Duffy, A., Freelon, D., Hussain, M.M., Mari, W. and Maziad, M. (2011), *Opening Closed Regimes: What Was the Role of Social Media during the Arab Spring?*, available at: SSRN 2595096.
- Hunt, S.A. and Benford, R.D. (2004), "Collective identity, solidarity, and commitment", *The Blackwell Companion to Social Movements*, pp. 433-457.
- Hussain, M.M. and Howard, P.N. (2013), *Democracy's Fourth Wave? Digital Media and the Arab Spring*, Oxford University Press, New York.
- Huysman, M. and Wulf, V. (2006), "IT to support knowledge sharing in communities, towards a social capital analysis", *Journal of Information Technology*, Vol. 21 No. 1, pp. 40-51.
- Kietzmann, J.H., Hermkens, K., McCarthy, I.P. and Silvestre, B.S. (2011), "Social media? Get serious! Understanding the functional building blocks of social media", *Business Horizons*, Vol. 54 No. 3, pp. 241-251.
- Kitchens, B., Johnson, S.L. and Gray, P. (2020), "Understanding echo chambers and filter bubbles: the impact of social media on diversification and partisan shifts in news consumption", *MIS Quarterly*, Vol. 44 No. 4, pp. 1619-1649.
- Klandermans, B. (1984), "Mobilization and participation: social-psychological expansions of resource mobilization theory", *American Sociological Review*, Vol. 49, pp. 583-600.
- Klandermans, B., Van der Toorn, J. and Van Stekelenburg, J. (2008), "Embeddedness and identity: how immigrants turn grievances into action", *American Sociological Review*, Vol. 73 No. 6, pp. 992-1012.
- Lee, G., Shao, B.B. and Vinze, A. (2018), "The role of ICT as a double-edged sword in fostering societal transformations", *Journal of the Association for Information Systems*, Vol. 19 No. 3, pp. 209-246.
- Lichbach, M.I. (1996), *The Cooperator's Dilemma*, University of Michigan Press, Ann Arbor.
- Lim, M. (2012), "Clicks, cabs and coffee houses: social media and oppositional movements in Egypt, 2004-2011", *Journal of Communication*, Vol. 62 No. 2, pp. 231-248.

- Lindell, M.K. and Whitney, D.J. (2001), "Accounting for common method variance in cross-sectional research designs", *Journal of Applied Psychology*, Vol. 86 No. 1, p. 114.
- Lohmöller, J.B. (1989), *Latent Variable Path Modeling with Partial Least Squares*, Physica, Heidelberg.
- Lowry, P.B. and Gaskin, J. (2014), "Partial least squares (PLS) structural equation modeling (SEM) for building and testing behavioral causal theory: when to choose it and how to use it", *IEEE Transactions on Professional Communication*, Vol. 57 No. 2, pp. 123-146.
- Lukashina, Y. (2013), "Collective action frames and Facebook fan and group pages: the case of the Russian Snow Revolution 2011-2013", *Interface: A Journal on Social Movements*, Vol. 5 No. 2, pp. 422-449.
- MacCarthy, M.N. and Zald, J.D. (1979), *The Dynamics of Social Movements*, Winthrop, Cambridge.
- Maghrabi, R. and Salam, A. (2013), "Social media and citizen social movement process for political change: the case of 2011 Egyptian revolution", *ICIS*, Milan, pp. 1-11.
- Majchrzak, A., Faraj, S., Kane, G.C. and Azad, B. (2013), "The contradictory influence of social media affordances on online communal knowledge sharing", *Journal of Computer-Mediated Communication*, Vol. 19 No. 1, pp. 38-55.
- Malhotra, N.K., Kim, S.S. and Patil, A. (2006), "Common method variance in IS research: a comparison of alternative approaches and a reanalysis of past research", *Management Science*, Vol. 52 No. 12, pp. 1865-1883.
- McCarthy, M.N. and Zald, J.D. (1979), *The Dynamics of Social Movements*, Winthrop, Cambridge.
- Morozov, E. (2011), *The Net Delusion: How Not to Liberate the World*, Penguin, London.
- Nekmat, E. and Ismail, I. (2019), "Issue-based micromobilization on social media: mediated pathways linking issue involvement and self-network opinion congruity to expressive support", *Computers in Human Behavior*, Vol. 101, pp. 51-59.
- Nitzl, C. (2016), "The use of partial least squares structural equation modelling (PLS-SEM) in management accounting research: directions for future theory development", *Journal of Accounting Literature*, Vol. 37, pp. 19-35.
- Nitzl, C., Roldan, J.L. and Cepeda, G. (2016), "Mediation analysis in partial least squares path modeling: helping researchers discuss more sophisticated models", *Industrial Management and Data Systems*, Vol. 116 No. 9, pp. 1849-1864.
- Nunnally, J.C. and Bernstein, I.H. (1994), *Psychometric Theory*, McGraw-Hill, New York.
- Oh, O., Eom, C. and Rao, H.R. (2015), "Role of social media in social change: an analysis of collective sense making during the 2011 Egypt revolution", *Information Systems Research*, Vol. 26 No. 1, pp. 210-223.
- Olson, M. (1965), *The Logic of Collective Action: Public Goods and the Theory of Groups*, Harvard University Press, Cambridge, MA.
- Pandey, V., Gupta, S. and Chattopadhyay, M. (2019), "A framework for understanding citizens' political participation in social media", *Information Technology and People*, Vol. 33 No. 4, pp. 1053-1075.
- Petter, S., Straub, D.W. and Rai, A. (2007), "Specifying formative constructs in information systems research", *MIS Quarterly*, Vol. 31 No. 4, pp. 623-656.
- Pingree, R.J. (2007), "How messages affect their senders: a more general model of message effects and implications for deliberation", *Communication Theory*, Vol. 17 No. 4, pp. 439-461.
- Podsakoff, P.M., MacKenzie, S.B., Lee, J.-Y. and Podsakoff, N.P. (2003), "Common method biases in behavioral research: a critical review of the literature and recommended remedies", *Journal of Applied Psychology*, Vol. 88 No. 5, p. 879.
- Putnam, R.D. (2001), *Bowling Alone: The Collapse and Revival of American Community*, Simon & Schuster, New York.

- Reicher, S., Spears, R. and Haslam, S.A. (2010), *The Social Identity Approach in Social Psychology*, Sage Identities Handbook, pp. 45-62.
- Ringle, C.M., Wende, S. and Becker, J.-M. (2015), *SmartPLS 3*, Bönningstedt.
- Schumann, S. and Klein, O. (2015), "Substitute or stepping stone? Assessing the impact of low-threshold online collective actions on offline participation", *European Journal of Social Psychology*, Vol. 45 No. 3, pp. 308-322.
- Segeberg, A. and Bennett, W.L. (2011), "Social media and the organization of collective action: using Twitter to explore the ecologies of two climate change protests", *The Communication Review*, Vol. 14 No. 3, pp. 197-215.
- Selander, L. and Jarvenpaa, S. (2013), "Online impulse activism at amnesty international", *International Conference on Information Systems (ICIS)*, Milan, pp. 1-10.
- Selander, L. and Jarvenpaa, S.L. (2016), "Digital action repertoires and transforming a social movement organization", *MIS Quarterly*, Vol. 40 No. 2, pp. 331-352.
- Shafiq, M.N., Mason, J., Seybolt, T. and DeLuca, K. (2014), "Are student protests in arab states caused by economic and political grievances? Empirical evidence from the 2006-07 arab barometer", *Peabody Journal of Education*, Vol. 89 No. 1, pp. 141-158.
- Shirazi, F. (2013), "Social media and the social movements in the Middle East and North Africa", *Information Technology and People*, Vol. 26 No. 1, pp. 28-49.
- Skoric, M.M., Zhu, Q. and Pang, N. (2016), "Social media, political expression, and participation in Confucian Asia", *Chinese Journal of Communication*, Vol. 9 No. 4, pp. 331-347.
- Snow, D., Rochford, E., Jr., Worden, S. and Benford, R. (1986), "Frame alignment processes, micromobilization, and movement participation", *American Sociological Review*, Vol. 51 No. 4, pp. 464-481.
- Snow, D., Benford, R., McCammon, H., Hewitt, L. and Fitzgerald, S. (2014), "The emergence, development, and future of the framing perspective: 25+ years since frame alignment", *Mobilization: An International Quarterly*, Vol. 19 No. 1, pp. 23-46.
- Stamati, T., Papadopoulos, T. and Anagnostopoulos, D. (2015), "Social media for openness and accountability in the public sector: cases in the Greek context", *Government Information Quarterly*, Vol. 32 No. 1, pp. 12-29.
- Steinberg, M.W. (1998), "Tilting the frame: considerations on collective action framing from a discursive turn", *Theory and Society*, Vol. 27 No. 6, pp. 845-872.
- Stürmer, S. and Simon, B. (2004), "Collective action: towards a dual-pathway model", *European Review of Social Psychology*, Vol. 15 No. 1, pp. 59-99.
- Tajfel, H.E. (1978), "Social categorization, social identity and social comparison", in Tajfel, H.E. (Ed.), *Differentiation between Social Groups: Studies in the Social Psychology of Intergroup Relations*, Academic Press, London, pp. 61-76.
- Tajfel, H. and Turner, J.C. (1986), "The social identity theory of intergroup behavior", in Worchel, S. and Austin, W.G. (Eds), *Psychology of Intergroup Relations*, 2nd ed, Nelson-Hall, Chicago, IL, pp. 7-24.
- Tausch, N., Becker, J.C., Spears, R., Christ, O., Saab, R., Singh, P. and Siddiqui, R.N. (2011), "Explaining radical group behavior: developing emotion and efficacy routes to normative and nonnormative collective action", *Journal of Personality and Social Psychology*, Vol. 101 No. 1, p. 129.
- Tufekci, Z. and Wilson, C. (2012), "Social media and the decision to participate in political protest: observations from Tahrir Square", *Journal of Communication*, Vol. 62 No. 2, pp. 363-379.
- Vaast, E., Safadi, H., Lapointe, L. and Negoita, B. (2017), "Social media affordances for connective action: an examination of microblogging use during the gulf of Mexico oil spill", *MIS Quarterly*, Vol. 41 No. 4, pp. 1179-1205.
- Vaccari, C., Valeriani, A., Barberá, P., Bonneau, R., Jost, J.T., Nagler, J. and Tucker, J.A. (2015), "Political expression and action on social media: exploring the relationship between lower-and higher-threshold political activities among Twitter users in Italy", *Journal of Computer-Mediated Communication*, Vol. 20 No. 2, pp. 221-239.

- Valenzuela, S. (2013), "Unpacking the use of social media for protest behavior: the roles of information, opinion expression, and activism", *American Behavioral Scientist*, Vol. 57 No. 7, pp. 920-942.
- Van der Stede, W.A., Young, M.S. and Chen, X.C. (2006), "Doing management accounting survey research", in Chapman, C.S., Hopwood, A.G. and Shields, M.D. (Eds), *Handbooks of Management Accounting Research*, Elsevier, Oxford, pp. 445-478.
- Van Zomeren, M., Postmes, T. and Spears, R. (2008), "Toward an integrative social identity model of collective action: a quantitative research synthesis of three socio-psychological perspectives", *Psychological Bulletin*, Vol. 134 No. 4, pp. 504-535.
- Wasko, M.M. and Faraj, S. (2005), "Why should I share? Examining social capital and knowledge contribution in electronic networks of practice", *MIS Quarterly*, Vol. 29 No. 1, pp. 35-57.
- Wilkins, D.J., Livingstone, A.G. and Levine, M. (2019), "All click, no action? Online action, efficacy perceptions, and prior experience combine to affect future collective action", *Computers in Human Behavior*, Vol. 91, pp. 97-105.
- Wold, H.O.A. (1982), "Soft modeling: the basic design and some extensions", in Joreskog, K.G. and Wold, H.O.A. (Eds), *Systems under Indirect Observation*, North-Holland, Amsterdam, pp. 1-54.

Reference*	Context	Impact on mobilisation	Variables and relationships of interest
Enjolras <i>et al.</i> (2013)	Examines how the use of SM affects participation in offline demonstrations using survey data from Norway	Mobilisation effect of SM use (esp. heavy use) for participants characterised by lower socioeconomic status and younger age	Considers individual-level characteristics with a structural view (mobilising agency) and the supplementary role of SM in comparison with other more established channels
Skoric <i>et al.</i> (2016)	Applies a meta-study of research on SM use and political participation and expression in 15 East Asian countries	Mobilisation effect of expressive use of SM and to a lesser degree of informational and relational uses	Examines different types of SM use (i.e. informational, expressive, relational and recreational), political expression and political participation (esp. offline)
Boulianne (2015)	Applies a meta-study of research on SM use and political participation based on 36 studies predominantly from established democratic systems	Mobilisation effect suggested but limited evidence on the relationship between SM use and offline collective action (protest-type activities)	Examines relationships between SM use and participation in civic and political life (election campaigns and protest-type activities) across political systems
Vaccari <i>et al.</i> (2015)	Examines whether political activities on SM deter from other forms of political engagement (slacktivists thesis) using survey data from Italy	Mobilisation effect of SM use (lower-threshold forms of political engagement), especially amongst the expressive users	Investigates relationships between lower- and higher-threshold political activities (online and offline)
Valenzuela (2013)	Examines a path model to protest behaviour using survey data from Chile	Mobilisation effect of SM use for opinion expression and activism (but not for gaining news)	Examines a mediation model including different types of SM use and protest behaviour
Wilkins <i>et al.</i> (2019)	Examines causal effects of connective actions on future political action based on a quasi-experimental design	Demobilisation effect of connective actions considering the same cause, but mobilisation effect for other causes under certain conditions (efficacy beliefs)	Calculates moderated mediation models including connective actions and collective actions (offline and online) as well as prior activism experience and efficacy perceptions
Schumann and Klein (2015)	Considers whether low-threshold connective actions derail subsequent offline collective actions on the basis of three different experiments	Demobilising effect of low-threshold connective actions (if already considered as a substantial contribution to the group's success)	Focus on different models including low-threshold connective actions, offline collective action willingness, in-group identification and satisfaction of group-enhancing motives
Baek (2015)	Investigates factors influencing electoral participation using survey data from South Korean	Mobilising effect of SM use for voting under certain conditions (stimulated by political messages of friends)	Considers type of SNS use, user characteristics and directionality of communication

Note(s): * - The eight studies listed in this table do not represent an exhaustive list of all research but were selected as representative examples that have been frequently cited in the literature

Table A1. Overview of social movement studies on mobilisation effects of connective action

Table A2.
Survey modes and
responses across
universities

University	Target populations	All returns			Completed returns		
		Hardcopies	Online	All	Hardcopies	Online	All
The American University in Cairo (AUC)	1,000	86	31	117	74	7	81
German University in Cairo (GUC)	470	27	121	148	24	41	65
Ain Shams University (ASU)	240	47	52	99	38	17	55
Total	1,710	160	204	364	136	65	201*

Note(s): *Seven were dropped due to aberrant response behaviour leaving 194 data sets for analysis

Table A3.
Definitions of model
constructs

Construct	Definition	Sources
<i>Content internalisation (CI) (formative)</i>	Connective actions for instantly and continuously gaining, validating or supplementing information	Harindranath <i>et al.</i> (2015)
<i>Content externalisation (CE) (formative)</i>	Connective actions for sharing self-selected or self-produced information	Harindranath <i>et al.</i> (2015)
<i>Interactive socialisation (IS) (formative)</i>	Connective actions for interactive communication, discussion and presenting personal thoughts and opinions	Harindranath <i>et al.</i> (2015)
<i>Perceived injustice (PI) (reflective)</i>	Extent to which an individual perceives injustice in terms of inequality or relative deprivation	Dubé and Guimond (1986), Van Zomeren <i>et al.</i> (2008)
<i>Perceived efficacy (PE) (reflective)</i>	Extent to which an individual believes in one's capacity to contribute to the movement	Bandura (1997), Ennis and Schreuer (1987)
<i>Social identity (SI) (reflective)</i>	Extent to which an individual identifies with his online social network	Van Zomeren <i>et al.</i> (2008), Ellemers <i>et al.</i> (1999)
<i>Offline collective action (CA) (reflective)</i>	Extent to which individuals have participated in physical activities of common interests to advance movement goals	Van Zomeren <i>et al.</i> (2008)

Perceived injustice

To what extent do you agree with the following in the context of the time after January 2011 and up to June 2013?

1. I think the way our people have been treated was unfair (PI1)
2. I have felt angry because of deprived rights and resources (PI2)
3. I have felt dissatisfied with our unequal society (PI3)

Perceived efficacy

After January 2011, how did you perceive your ability to contribute to a next movement?

1. I was confident about being able to contribute (PE1)
2. Contributing to the next revolution will be up to me (PE2)
3. I was confident that everybody can have a voice (PE3)

Social identity

To what extent do you agree with the following?

1. I have a high respect for the users of social media in Egypt (SI1)

Table A4.
Operationalisation of
model constructs

(continued)

2. I like to be part of social media networks in Egypt (SI2)
3. I like to tell others that I am part of social media networks in Egypt (SI3)

Connective action

I regularly used social media since the January 2011 revolution for this purpose . . .

1. To verify information and opinions (e.g. gained from traditional media) (CI1)
2. To get a more comprehensive view about the situation and developments (CI2)
3. To instantly and continuously gain new information on events and outcomes (CI3)
4. To engage in interactive communication and discussions in communities (IS1)
5. To portray to others freely my own thoughts and opinions (IS2)
6. To circulate selected content and share it with the communities (CE1)
7. To circulate self-produced content (e.g. videos or pictures) like an independent reporter (CE2)

Offline collective action

How active have you been in pursuing collective goals in the movements since January 2011?

1. I am supporting movements on the streets whenever necessary (CA1)
2. I am frequently active for the benefit of our society (CA2)
3. I am regularly taking part in events which can benefit our society (CA3)

Note(s): All items measured on a scale from “Strongly Disagree” (1) to “Strongly Agree” (7)

Table A4.

Latent construct	Composite reliability	AVE	PE	PI	SI	CA
Perceived efficacy (PE)	0.820	0.604	<i>0.777</i>			
Perceived injustice (PI)	0.898	0.746	0.305	<i>0.864</i>		
Social identity (SI)	0.901	0.754	0.225	0.068	<i>0.868</i>	
Collective action (CA)	0.896	0.743	0.435	0.266	0.255	<i>0.862</i>
Content internalisation (CI)	n/a	n/a	0.274	0.205	0.391	0.233
Content externalisation (CE)	n/a	n/a	0.353	0.358	0.284	0.328
Interactive socialisation (IS)	n/a	n/a	0.321	0.229	0.329	0.283

Note(s): Composite reliability (ρ_c) = $(\sum \lambda_i)^2 / [(\sum \lambda_i)^2 + \sum \text{var}(\epsilon_i)]$, where λ_i is the component loading to an indicator and $\text{var}(\epsilon_i) = 1 - \lambda_i^2$; AVE is the average variance extracted by latent constructs from their indicators; on the diagonal are the square roots of AVE in *Italic font* and in the lower left triangle are the correlations amongst latent constructs

Table A5.
Internal consistency, convergent and discriminant validity for reflective constructs

Scale items	PE	SI	PI	CA
PE1	<i>0.847</i>	0.228	0.225	0.426
PE2	<i>0.708</i>	0.079	0.367	0.266
PE3	<i>0.771</i>	0.196	0.142	0.298
SI1	0.131	<i>0.746</i>	0.061	0.163
SI2	0.208	<i>0.927</i>	0.079	0.253
SI3	0.231	<i>0.919</i>	0.041	0.237
PI1	0.316	0.040	<i>0.857</i>	0.307
PI2	0.246	0.054	<i>0.875</i>	0.155
PI3	0.223	0.085	<i>0.858</i>	0.221
CA1	0.296	0.155	0.253	<i>0.806</i>
CA2	0.389	0.268	0.278	<i>0.897</i>
CA3	0.426	0.222	0.162	<i>0.879</i>

Note(s): *Italic numbers* are the loadings of indicators on their own construct

Table A6.
Cross-loadings for reflective constructs

Table A7.
Outer weights and loadings, significance levels and VIF for formative constructs

Latent construct	Weights (outer loadings)	<i>p</i> -values	VIF
<i>Content internalisation (CI)</i>			
CI1	0.219 ^e (0.762)	0.081	2.329
CI2	0.215 ^e (0.788)	0.073	2.484
CI3	0.701** (0.947)	0.000	1.590
<i>Content externalisation (CE)</i>			
CE1	0.625** (0.922)	0.000	1.585
CE2	0.489** (0.868)	0.000	1.585
<i>Interactive socialisation (IS)</i>			
IS1	0.524** (0.880)	0.000	1.563
IS2	0.593** (0.908)	0.000	1.563
Note(s): ^e <i>p</i> < 0.1; * <i>p</i> < 0.05 and ** <i>p</i> < 0.01			

About the authors

Edward W.N. Bernroider is Professor of Management Information Systems and Head of the Institute of Information Management and Control at WU (Vienna University of Economics and Business) in Austria. His current research focusses on Information Systems governance and control in particular in global and cross-cultural contexts. He has engaged in a variety of educational programmes, international consultancies and advisory activities for commercial and non-profit enterprises and has co-organised and presented his work at numerous international conferences. Many of his publications have appeared in top-rated Information Systems and Operations Research journals. He currently serves on the editorial board of two leading journals and is a regular member of academic and professional bodies. Edward W.N. Bernroider is the corresponding author and can be contacted at: edward.bernroider@wu.ac.at

G. Harindranath is Professor of Information Systems in the School of Business and Management at Royal Holloway, University of London. Hari holds a PhD in information systems from the London School of Economics and Political Science (LSE) and his research centres on the social and organisational implications of digital technologies, including ICT4D. Hari is an editorial board member of the *Journal of Information Technology* and serves as associate/senior editor for *Information and Management* and *Information Technology & People*. He is a co-founder of the International Conference on Information Resources Management (Conf-IRM), which is an affiliated conference of the Association for Information Systems (AIS). Hari is currently leading a work package on digital technologies and migration within the UK-government funded project "Migration for development and equality" (MIDEQ).

Sherif Kamel is Professor of Management and Dean of the School of Business at the American University in Cairo. His research and teaching interests include digital transformation, information technology transfer to developing nations and entrepreneurship. His work is published in IS and management journals and books and he is the editor of three books. He is the associate editor of the *Journal of IT for Development* and the *Journal of Cases on Information Technology*. Kamel holds a PhD in Information Systems from the London School of Economics and Political Science, an MBA, a BA in business administration and an MA in Islamic Art and Architecture from The American University in Cairo.

For instructions on how to order reprints of this article, please visit our website:

www.emeraldgroupublishing.com/licensing/reprints.htm

Or contact us for further details: permissions@emeraldinsight.com